

hybrid
SIGN SYSTEM





HYBRID SIGN SYSTEM.

Hybrid | adjective: A combination of different elements with desirable characteristics.

Hybrid from Signbox® is a premium modular outdoor sign system that combines the relentlessly durable and sustainable qualities of exterior-grade bamboo with powerful materials, such as steel, glass and illumination, that bring both sign scheme and setting to life.

Engineered with components that are tailored from the ground up to support single post, twin post or bamboo beam structures, Signbox® Hybrid is a fusion of elegant, yet hardworking materials and an aesthetically-pleasing, versatile system design. Supporting panels of painted exterior grade MDF, bamboo, toughened glass or aluminium, with a series of precision engineered, stainless steel tamper proof fixings.

HYBRID SETS THE SCENE. EFFORTLESSLY.

Easy to design and with seamless, step-by-step installation, Hybrid creates groundbreaking impact and effects that blend with the environment – effortlessly.

Its graceful lines and nature-rich components make Hybrid the perfect modular sign system for discerning environments from landmark commercial buildings, hotels and hospitality areas to woodland settings, school and university campuses and ecologically-conscious public spaces.



THE BEAUTY OF BAMBOO.

Bamboo isn't just beautiful - it's stable, economical and remarkably sustainable. It's the fastest growing plant in the world and serves as the green, carbon-negative alternative to scarce hardwoods and even non-renewable resources from concrete and metals to plastics like PVC.

Bamboo is also incredibly tough - with a weather resistance that will out-perform the best quality tropical hardwoods, bamboo has the perfect ecological credentials for exterior signage solutions that need to stay looking good for years.

THE TECHNICAL DETAIL.

Side illumination is provided with an elegant and effective IP67 flexible LED strip. Hybrid beams are machined to accept the 5mm wide, 12v silicon extrusion which is available in 6 bright, even, colours.

The low voltage wiring is concealed within the post and terminates in an IP rated connection box at ground level.

Panels and planks can be fabricated from painted MDF, aluminium, toughened glass, slate or natural composite bamboo. Graphics and text can be routed, printed or self adhesive vinyl.

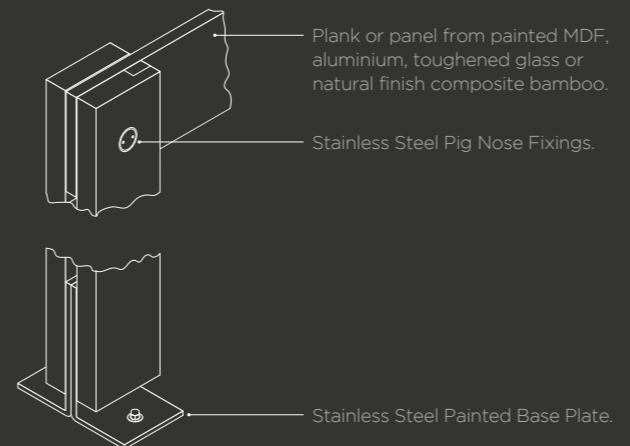

LED flexible illumination

Illuminated at dusk



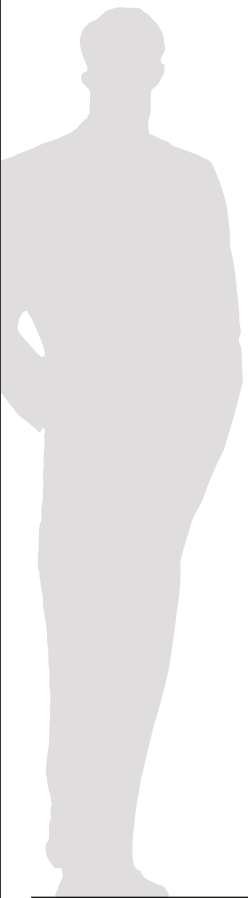

Mini lectern
Display size:
200mm wide



Maxi lectern
Display size:
390mm wide

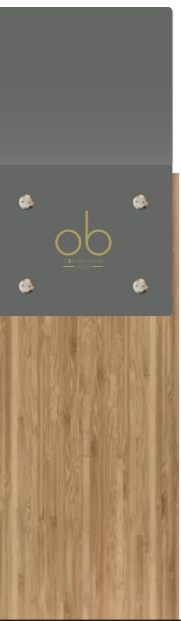

Bespoke lectern
Display size up to
900mm wide



Glass totem
wayfinder



Hybrid beam totem
2000mm x 390mm
x 50mm

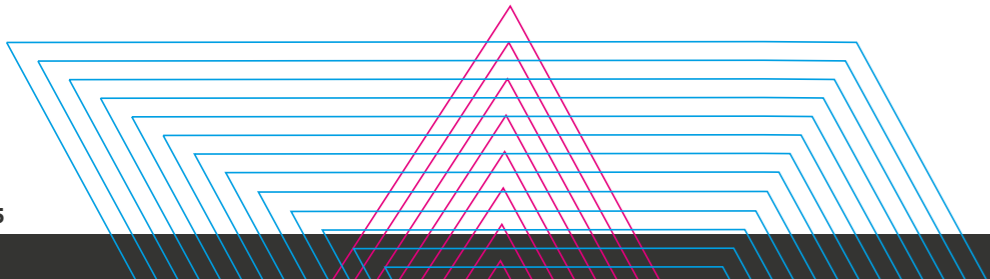

BEAM DIMENSIONS:

Hybrid beams are currently available in the following dimensions:

- 2000mm x 120mm x 38mm
- 2000mm x 390mm x 50mm
- 4000mm x 200mm x 50mm

The high stability of Signbox® Bamboo Solid Beams allows for creative use in both decorative and structural applications. With a service life of 25 years, treated in-ground, our hybrid sign system can be set in concrete footings or supplied with a powder coated aluminium foot for hard landscape installations.

The twin 120mm wide beam can support panels up to 3000mm high and the single 200mm wide beam is perfect for totem markers or flag signs.

Bespoke sized beams are easy to process for specific requirements, please contact our sales team for project enquiries.

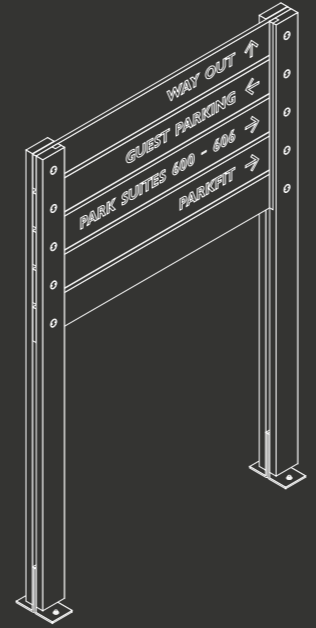



SIGN BEAM SOLAR LIGHT.

Hybrid | adjective: A combination of different elements with desirable characteristics.

Combine the 200mm wide sign beam with our beautifully designed and engineered solar powered light for both commercial and residential waymarking and illuminated signage.

Competitively priced and simple to install, this product provides safety, comfort and guidance with zero energy costs and zero CO₂ emissions. With the additional benefit of significant savings for groundwork and cable costs to run power to a remote location.

- Solar panel power - 5.5V/4.7W
- battery capacity - 5.2AH
- colour temp - 2500k
- light distribution - 500LM
- discharge time - 36hrs
- working temp - -25 - + 65C
- product size 265 x 195 x 155mm
- finish - gun metal metallic grey
- 2 yr warranty
- battery management system
- waterproof level - IP66





SignBOO – a sustainable and innovative internal sign system

Complementing the Hybrid external sign system, Signbox has developed SignBOO, a contemporary range of internal wayfinding specifically designed for the Hotel and Spa sector. Manufactured from 7mm thick composite bamboo sheet, graphics can be stencil cut on a CAD router, laser engraved or UV direct to surface printed on our Durst Rho P160. With a beautifully detailed, natural appearance, bamboo provides a hard and durable surface with high stability and less shrinkage than traditional hard wood species. SignBOO offers a broad collection of design opportunity, with complementary finishes like satin etched glass, acrylic, slate, brass, copper, corten or stainless steel. Available in a sheet size of 2440mm x 1220mm, SignBOO can be manufactured to suit bespoke dimensions and requirements for any project. SignBOO offers a clear sustainable advantage and is proven to be CO₂ neutral over the full life cycle. The inclusion of Signbox Bamboo Products contributes to a higher LEED, BREEAM or Green Star certification score for green building products.

Sustainability is more than just material

At Signbox, we believe that sustainability is a part of our business improvement process in every aspect from products to people to profitability. From our photovoltaic roof panels, powering our state-of-the-art machinery to a comprehensive recycling program to reclaim production waste and selection of eco-friendly products; we offer a holistic approach to environmental print and manufacture., creating a more responsible supply chain.



For more information contact:

Signbox Limited
 1-3 Egham Business Village
 Crabtree Road, Egham
 Surrey, TW20 8RB

t. +44 (0)1784 438688
 e. sales@signbox.co.uk
 w. www.signbox.co.uk

SIGNBOX®
 leading in the
 development of
 innovative and
 sustainable
 bamboo products

Signbox® Bamboo Products offer clear sustainability advantages and are even proven to be CO₂ neutral over the full life cycle! The inclusion of Signbox® Bamboo Products contributes to a higher LEED, BREEAM or Green Star certification score for green building projects.

